

Instruction Manual

Turbo Instrument Controller (TIC) Relay Box



Description	Item Number
TIC Setpoint Relay Box	D397-00-804
TIC Six Setpoint Relay Box	D397-01-804
TIC Pump Relay Box	D397-11-805
TIC Combined Relay Box	D397-21-806





Declaration of Conformity

We, BOC Edwards,
Manor Royal,
Crawley,
West Sussex RH10 2LW, UK

declare under our sole responsibility that the product(s)

TIC Setpoint Relay Box	D397-00-804
TIC Six Setpoint Relay Box	D397-01-804
TIC Pump Relay Box	D397-11-805
TIC Combined Relay Box	D397-21-806

to which this declaration relates is in conformity with the following standard(s)
or other normative document(s)

EN61010-1:2001	Safety requirements for electrical equipment for measurement, Control and laboratory use – Part 1: General requirements.
----------------	---

following the provisions of

73/023/EEC 89/336/EEC	Low Voltage Directive Electromagnetic Compatibility Directive
--------------------------	--

Dr. S.E. Ormrod, Technical Director

Crawley, 19th February 2007

Date and Place

Contents

Section	Page
1 INTRODUCTION	1
1.1 Scope and definitions	1
1.2 Description	1
1.2.1 3 Setpoint Relay Box	1
1.2.2 6 Setpoint Relay Box	2
1.2.3 Pump Relay Box	2
1.2.4 Combined Relay Box	2
2 TECHNICAL DATA	3
2.1 Operating and Storage Data	3
2.2 Mechanical Data	3
2.3 Connections	3
2.3.1 TIC Logic Interface Connector	3
2.3.2 User Logic Interface Connector	3
2.3.3 Mains Input (for Backing Pump and Heater Band only)	3
2.3.4 Heater Band Outlet	4
2.3.5 Backing Pump Outlet	4
2.3.6 Setpoint Connector	4
2.3.7 6 Setpoint Connector	5
2.3.8 Backing Line Isolation Valve Connection	6
3 INSTALLATION	7
3.1 Unpack and Inspect	7
3.2 Fitting the Relay Box	7
4 CONTROLLER ELECTRICAL CONNECTIONS	9
4.1 General	9
4.1.1 Additional Earth Bonding	9
4.1.2 Connecting to a TIC	9
4.1.3 Connecting the User Interface	9
4.2 Pump Functions	11
4.2.1 Connecting the Electrical Supply	11
4.2.2 Connecting a Backing Pump	11
4.2.3 Connecting to a Heater Band	11
4.2.4 Connecting an Isolation Valve	12
4.3 Setpoint Functions	12
4.3.1 Setpoint Connector Assembly	13
5 MAINTENANCE	15
5.1 Safety	15
5.2 Replacing a Fuse	15
5.2.1 Replacing the Backing Pump Fuse	15
5.2.2 Replacing the Heater Band Fuse	15
5.3 Cleaning the Relay Box	15
6 STORAGE AND DISPOSAL	17
6.1 Storage	17
6.2 Disposal	17
7 SERVICE, SPARES AND ACCESSORIES	19

eg/6013/10/08

7.1	Service	19
7.2	Spares	19
7.3	Accessories	19

For return of equipment, complete the HS Forms at the end of this manual.

Illustrations

Figure		Page
1	Pin Connections for a Positronic PLC Plug	4
2	Pin Connections for a Positronic PLC Plug	5
3	Pin Connections for a 3-way DIN Socket	6
4	Installation Dimensions	8
5	Installation Into a 19" Rack	8
6	Rear Panel of the Relay Box	10
7	Rear Panel of the 6 Setpoint Relay Box	10
8	Connector Assembly After Strain Relief Tightened	13

Tables

Table		Page
1	Setpoint Connector Pin-Out	4
2	6 Setpoint Connector Pin-Out	5
3	Isolation Valve Connector Pin-Out	6
4	Checklist of Components	7
5	Relevant Sections	11

Associated publications

Publication title	Publication number
Vacuum pump and vacuum system safety	P300-20-000

1 INTRODUCTION

1.1 Scope and definitions

This manual provides installation, operation and maintenance instructions for the Edwards Turbo Instrument Controller (TIC) Relay Box. You must use the Relay Box as specified in the manual.

Read this manual before you install and operate the Relay Box. Important safety information is highlighted as WARNING and CAUTION instructions; you must obey these instructions. The use of WARNINGS and CAUTIONS is defined below.



WARNING

Warnings are given where failure to observe the instruction could result in injury or death to people.

CAUTION

Cautions are given where failure to observe the instruction could result in damage to the equipment, associated equipment and process

The following IEC warning labels appear on the pump:



Warning - refer to accompanying documentation.



Warning - Edwards offer European customers a recycling service.

The units used throughout this manual conform to the SI international system of units of measurement.

1.2 Description



WARNING

Improper use of the equipment could cause damage to it or injury to people. The user is responsible for the safe operation and monitoring of the system.

The range of relay boxes described in this manual support the Edwards TIC controllers. The four TIC Relay Boxes have a variety of features that enhance the control capability of the TIC controllers.

1.2.1 3 Setpoint Relay Box

The 3 Setpoint Relay Box can be used with all seven TIC controllers. The relays are linked to the open collector outputs, which in turn can be configured through the controller.

1.2.2 6 Setpoint Relay Box

The 6 Setpoint Relay Box can be used with any of the Instrument ONLY controllers. The relays are linked to the open collector outputs, which in turn can be configured through the controller.

1.2.3 Pump Relay Box

The Pump Relay Box can be used with the TIC turbo or the TIC turbo and instrument controllers. The Relay Box acts as the control interface between the controller and:

- Mains backing pump
- Heater band
- Backing line isolation valve

1.2.4 Combined Relay Box

The Combined Relay Box can be used with all seven TIC controllers but only the functions of the TIC controller used will be available. For the Turbo and Instrument controller all the features of both the 3 Setpoint and Pump Relay Boxes can be used.

2 TECHNICAL DATA

2.1 Operating and Storage Data

Ambient operating temperature range	0°C to 40°C
Ambient storage temperature range	-30°C to 70°C
Maximum ambient operating humidity	Max. 90% RH non-condensing at 40°C
Maximum operating altitude	3000m
IP rating	20
IEC Rated Pollution Degree	2

2.2 Mechanical Data

Weight	
TIC 3 Setpoint Relay Box	564 g
TIC 6 Setpoint Relay Box	690 g
TIC Pump Relay Box	695 g
TIC Combined Relay Box	695 g
Size	106 mm x 128 mm x 113 mm (WxHxD) (3U high, 1/4 19" subrack)

2.3 Connections

2.3.1 TIC Logic Interface Connector

Connector type	25-way sub-miniature 'D' type plug
----------------	------------------------------------

Note: This connector is used to connect the Relay Box to the TIC. Refer to the TIC instruction manual 'Logic Interface' for details about the pinout and rating.

2.3.2 User Logic Interface Connector

Connector type	25-way sub-miniature 'D' type socket
----------------	--------------------------------------

Note: This connector is wired straight through from the 'TIC Logic Interface Connector' to allow further system integration. Refer to the TIC instruction manual 'Logic Interface' for details about the pinout and rating.

2.3.3 Mains Input (for Backing Pump and Heater Band only)

Connector type	CEE/IEC320 inlet
Maximum rating	240 V a.c.

2.3.4 Heater Band Outlet

Connector type	CEE/IEC320 outlet
Maximum rating	240V a.c. , 1A
Fuse	20mm x 5mm, 250V, 1A type F

Note: Backing pump fuse must also be fitted and functional to allow Heater Band to operate.

2.3.5 Backing Pump Outlet

Connector type	CEE/IEC320 outlet
Maximum rating	240 V a.c. , 10 A
Fuse	20 mm x 5 mm, 250 V, 10 A type T

2.3.6 Setpoint Connector

Connector type	12-way Positronic PLC plug
Maximum rating	250 V a.c. , 3 A (resistive) 30 V d.c. , 3 A (resistive)
Mating half (supplied)	12-way Positronic PLC socket with hood
Termination type	Solder bucket
Wire size	2 mm ² maximum (16 AWG)

Figure 1 - Pin Connections for a Positronic PLC Plug

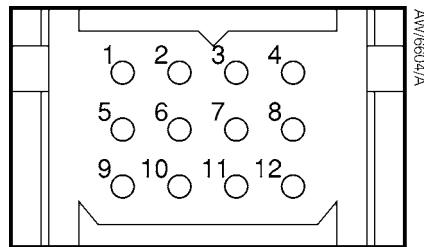

Table 1 - Setpoint Connector Pin-Out

Pin	Allocation
1	Protective earth
2	Setpoint 1 normally open
3	Setpoint 1 common
4	Setpoint 1 normally closed
5	Protective earth
6	Setpoint 2 normally open
7	Setpoint 2 common
8	Setpoint 2 normally closed
9	Protective earth
10	Setpoint 3 normally open
11	Setpoint 3 common
12	Setpoint 3 normally closed

2.3.7 6 Setpoint Connector

Connector type	24-way Positronic PLC plug
Maximum rating	250 V a.c., 5 A (resistive) * 30 V d.c., 5 A (resistive) *
Mating half (supplied)	24-way Positronic PLC socket with hood
Termination type	Solder bucket
Wire size	2 mm ² maximum (16 AWG)

* For inductive loads the peak current must be less than 14 A. The relay outputs can be used to switch the complete range of Edwards LCPVEK valves (a.c. or d.c.) and all Edwards PVEK valves.

Figure 2 - Pin Connections for a Positronic PLC Plug

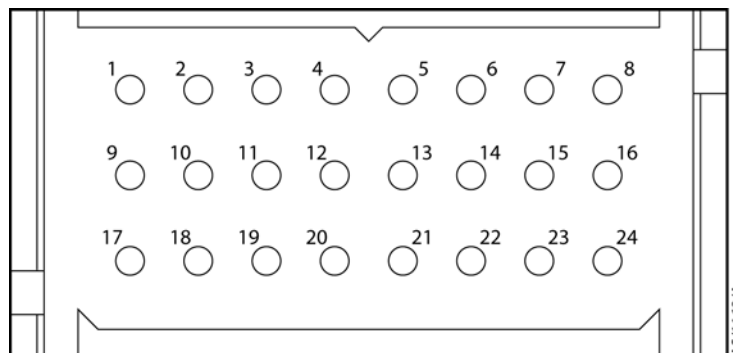

Table 2 - 6 Setpoint Connector Pin-Out

Pin	Allocation
1	Protective earth
2	Setpoint 1 normally open
3	Setpoint 1 common
4	Setpoint 1 normally closed
5	Protective earth
6	Setpoint 2 normally open
7	Setpoint 2 common
8	Setpoint 2 normally closed
9	Protective earth
10	Setpoint 3 normally open
11	Setpoint 3 common
12	Setpoint 3 normally closed
13	Protective earth
14	Setpoint 4 normally open
15	Setpoint 4 common
16	Setpoint 4 normally closed
17	Protective earth
18	Setpoint 5 normally open
19	Setpoint 5 common
20	Setpoint 5 normally closed
21	Protective earth
22	Setpoint 6 normally open
23	Setpoint 6 common
24	Setpoint 6 normally closed

2.3.8 Backing Line Isolation Valve Connection

Connector type	3-way DIN socket
Maximum rating	24 V d.c., 0.5 A
Lead Type	3 core 0.5mm ²

Figure 3 - Pin Connections for a 3-way DIN Socket

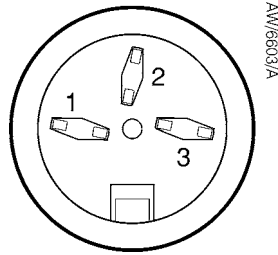

Table 3 - Isolation Valve Connector Pin-Out

Pin	Allocation
1	+24 V
2	Chassis
3	0 V

2.3.9 Earth Connection

Earth Stud	M4
------------	----

3 INSTALLATION

3.1 Unpack and Inspect

Remove all of the packaging material and check the Relay Box. If the Relay Box is damaged, follow the Edwards return of equipment procedures that are laid out in the back of this manual. Do not use the Relay Box if it is damaged.

Check that your package contains items that are listed in Table 4. If any of these items are missing, notify your supplier in writing within three days. If the Relay Box is not to be used immediately, store it in suitable conditions as described in Section 6.

3.2 Fitting the Relay Box



WARNING

If access to the IEC connector is restricted an additional isolation device should be provided, which will be easily accessible and identifiable by an operator.



WARNING

Ensure that all electrical wiring is safely secured so that people cannot trip on them. If you do not, it may cause injury to people.

CAUTION

This unit is IP20 rated. Please ensure that the unit is not installed where fluids can enter into the controller.

The Relay Box can be used on a bench-top or can be fitted in a rack or cabinet. Figure 4 shows the dimensions that are required for bench-top use. Figure 5 shows how the Relay Box can be mounted in a 19" rack.

If the Relay Box is to be fitted in a rack or cabinet, attach the Relay Box using four M2.5 screws, fitted through the mounting holes on the front face. If the Relay Box is to be used on a desk, fit 2 of the non-slip feet to the rear corners of the underside to help prevent the Relay Box from sliding about.

Note: Allow 80mm at the rear of the Relay Box for cables.

Table 4 - Checklist of Components

Quantity	Description	Check(✓)
1	Instruction Manual	<input type="checkbox"/>
1	Relay Box	<input type="checkbox"/>
4	Non-slip feet	<input type="checkbox"/>
For Setpoint and Combined Relay Boxes only:		
1	Setpoint connector kit comprising:	
1	Connector socket body	<input type="checkbox"/>
1	Backshell bottom half (with strain relief clamp)	<input type="checkbox"/>
1	Backshell top half	<input type="checkbox"/>
1	Insulation boot	<input type="checkbox"/>
2	Backshell screws	<input type="checkbox"/>

Table 4 - Checklist of Components

Quantity	Description	Check(✓)
14 or 26 (as appropriate)	Contacts	<input type="checkbox"/>
1	Contact extraction tool	<input type="checkbox"/>
2	Cable ties	<input type="checkbox"/>
For Pump and Combined Relay Boxes only:		
1	Isolation valve lead (3-way DIN plug with 2m lead)	<input type="checkbox"/>

Figure 4 - Installation Dimensions

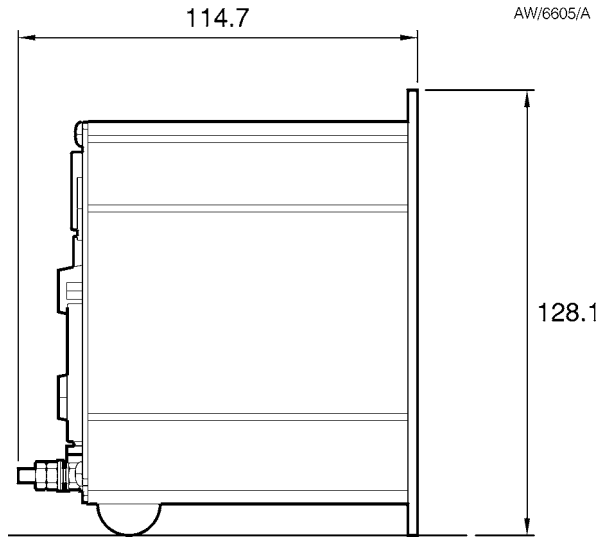
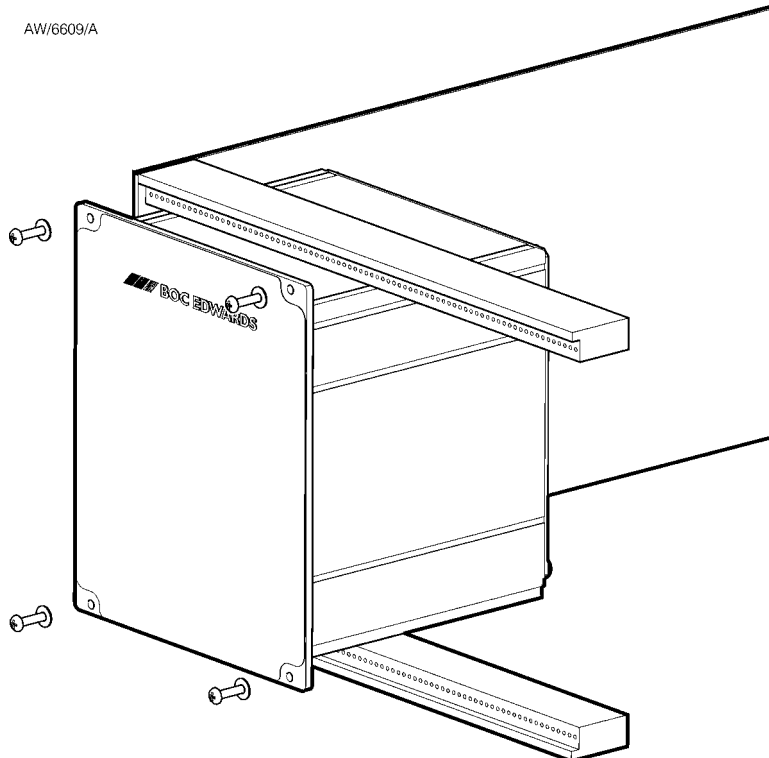

Figure 5 - Installation Into a 19" Rack



4 CONTROLLER ELECTRICAL CONNECTIONS

CAUTION

When making connections to the Relay Box, ensure that the TIC is switched off to prevent the unexpected operation of pumps etc.

Depending on the type of Relay Box purchased, not all of the following sections will apply. Refer to Table 5 for a description of the relevant sections.

4.1 General

4.1.1 Additional Earth Bonding

The electrical supply cable normally provides protective earthing for electrical safety. If this is not the case, or if additional earth bonding is required, then the earth stud on the rear of the Relay Box (Figure 6, item 7) should be connected to your vacuum system earth.

Connect a suitably earthed cable between the two washers fitted to the earth stud on the rear of the Relay Box and lock them in place with the two nuts.

Note: Do not remove the bottom nut from the earth stud.

4.1.2 Connecting to a TIC

The Relay Box can be connected to your TIC via a 25-way logic interface lead, available from Edwards. Refer to Section 7.3.

Ensure that power to the TIC is switched off. If anything is connected to the TIC logic interface, it will need to be removed from the TIC and connected to the 'User' interface of the Relay Box.

Connect the 25-way logic interface lead between the Relay Box 'TIC Logic Interface' and the logic interface on the TIC.

Note: The 'User' interface of the Relay Box must have either, the 'Logic Interface Plug' that was supplied with the TIC, or the users own connector fitted, to clear the interlocks and enable the system to operate.

4.1.3 Connecting the User Interface

The User Logic Interface on the Relay Box offers the same functionality as the Logic Interface on the TIC. Refer to the TIC instruction manual for details of this connector.

Figure 6 - Rear Panel of the Relay Box

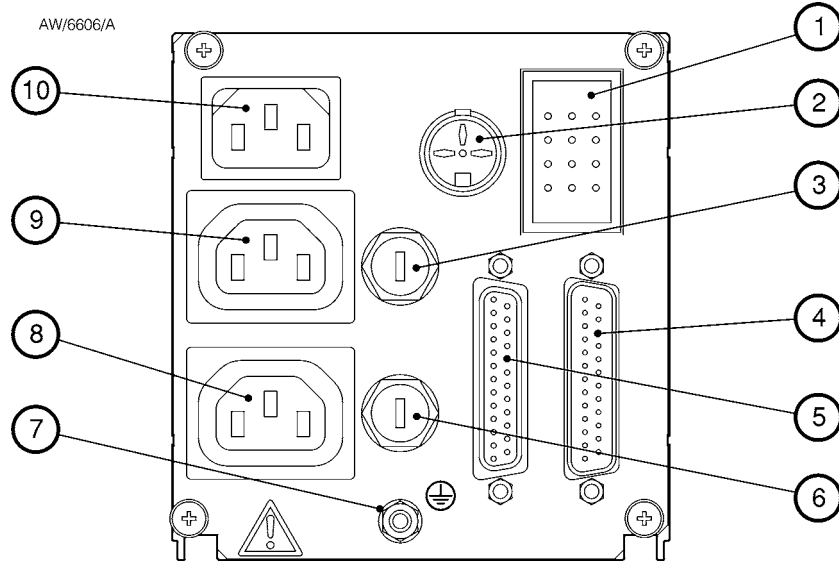

- 1. Setpoint relay connection*
- 2. Isolation valve connection†
- 3. Backing pump fuse F1†
- 4. TIC logic interface connection
- 5. User logic interface
- 6. Heater band fuse F2†
- 7. Earth stud
- 8. Heater band connection†
- 9. Backing pump connection†
- 10. Power supply connection†

*. Setpoint and combined relay boxes only.
 †. Pump and combined relay boxes only.

Figure 7 - Rear Panel of the 6 Setpoint Relay Box

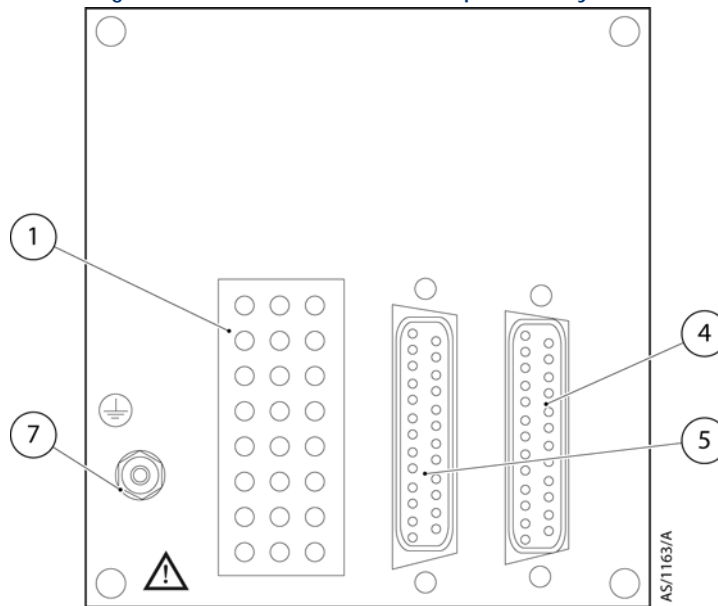

- 1. Setpoint relay connection
- 4. TIC logic interface connection
- 5. User logic interface
- 7. Earth stud

Table 5 - Relevant Sections

Relay box	General	Pump functions	Setpoint functions
Pump relay box	✓	✓	
Setpoint relay box (3 and 6)	✓		✓
Combined relay box	✓	✓	✓

4.2 Pump Functions

4.2.1 Connecting the Electrical Supply



WARNING

High voltages exist in the Relay Box. Ensure that it is adequately earthed and observe all appropriate safety precautions for the safe installation and handling of electrical equipment. If you do not, there will be a danger of injury or death to people by electric shock.

The electrical supply to the Relay Box is switched by internal relays and fed out to the heater band and backing pump outlets.

Ensure that the electrical supply to the TIC is switched to 'off' before making any connections to the Relay Box. Connect the Relay Box to the electrical supply with an appropriate supply cable.

The supply cable used must be rated to handle the combined power of the heater band and backing pump.

4.2.2 Connecting a Backing Pump

CAUTION

The backing pump outlet is supplied at the same voltage as the Relay Box mains inlet. Ensure that the pump is set for the correct operating voltage before connection is made.

Ensure that fuse F1 fitted to the Relay Box is suitable for the pump being used. Refer to the pump instruction manual for further information on correct fuse selection.

Connect a pump supply cable between the backing pump outlet on the Relay Box and the backing pump.

4.2.3 Connecting to a Heater Band



WARNING

Ensure that the heater band and backing pump are connected to the correct IEC connector. If you do not there may be danger of injury to people by burns.

CAUTION

The heater band outlet is supplied at the same voltage as the Relay Box mains inlet. Ensure that the heater band is suitable for the supply being used.

Ensure that fuse F2 fitted to the Relay Box is suitable for the heater band being used. Refer to the heater band instruction manual for further information on correct fuse selection.

Connect the heater band plug to the heater band output on the Relay Box.

Note: For the heater band to operate, both the fuses (F1 and F2) in the Relay Box must be fitted and functional.

4.2.4 Connecting an Isolation Valve

The Relay Box can supply 24 V d.c. to operate a backing line isolation valve. The valve will be energised whenever the backing pump is running.

Refer to the isolation valve instructions and connect the isolation valve lead to the valve as follows:

Green/Yellow	Valve earth terminal (terminal 1)
Blue	Valve terminal 2
Brown	Valve terminal 3

Once the valve body has been reassembled, plug the isolation valve DIN connector into the isolation valve output on the Relay Box.

4.3 Setpoint Functions



WARNING

If hazardous voltages are to be used on the setpoint connector, additional precautions should be taken to ensure that the operator cannot come into contact with the face of the setpoint connector socket.



WARNING

Do not mix hazardous and low voltages on the setpoint connector as the insulation between channels is not adequate to guarantee safety. Mixing hazardous and low voltages will lead to a risk of electrocution to operators.



WARNING

If using the setpoint connector for hazardous voltages, it is vital that the Relay Box is earthed independently via the earth stud. This holds true even if the setpoint connector earth pins are used or if the IEC mains inlet is used.



WARNING

Setpoint connections are un-fused. Overcurrent protection must be provided to protect the wiring and Relay Box. For a 12-way connector this should be 3 A or less. For a 24-way connector this should be 5 A or less.



WARNING

If the setpoint connector is used with hazardous voltages the voltage source(s) must include an easily accessible isolation device in close proximity and marked as the disconnecting device for the equipment.



WARNING

If the setpoint connector is used with hazardous voltages the equipment connected to it must provide insulation rated for the voltage (or greater).

4.3.1 Setpoint Connector Assembly



WARNING

Ensure all power is removed from the setpoint connector before removing or disassembling the connector, or inserting the extraction tool.

Solder the connection wires into the contacts, ensuring that no solder is left on the outside of the contact body. Push the wires with contacts through the insulating boot. If the boot opening is not large enough, the wires should be removed and the boot cut to size.

After the wires are fitted through the boot, the boot should be pushed up the cable. Push the contacts into the appropriate positions in the connector body from the rear. In order to latch the contact rears need to be slightly recessed into the connector body.

Once all of the connections have been made, the lower half of the backshell should be fitted and the strain relief arranged to grip the wires. See [Figure 8](#). Tighten the strain relief clamp to hold the wires securely.

Attach the top half of the backshell and screw the two halves of the backshell together using the screws supplied.

Slide the insulating boot over the assembled connector and use a cable tie to hold the boot in place over the connector.

Note: The boot may be very tight.

If any of the connections need to be changed, the extraction tool can be used to remove the contact. With the connector backshell removed, insert the extraction tool into the front of the connector body, over the contact to be removed. Once it is fully pushed home, depress the plunger to release the contact.

Figure 8 - Connector Assembly After Strain Relief Tightened

AW/6607/A

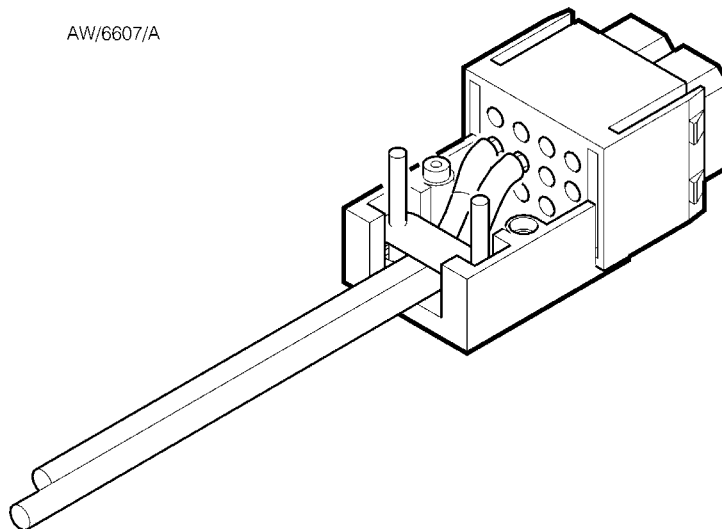

This page has been intentionally left blank.

5 MAINTENANCE

5.1 Safety



WARNING

Obey the safety instructions given below and take note of the proper precautions. If you do not you could cause injury to people and damage to equipment.

There are no serviceable parts in the Relay Box. Do not open. Return to your nearest Edwards service centre for any repairs that are necessary.

The Edwards return of equipment forms can be found at the rear of this manual.

5.2 Replacing a Fuse



WARNING

Disconnect all power sources from the relay box before removing or replacing fuses.

If one of the electrical fuses fails, replace it by following the instructions given below. If the fuse fails immediately after being replaced, a fault is likely to have developed in the connected equipment, determine the nature of this fault and rectify it before replacing the fuse again.

In the unlikely event of the fault being traced to the Relay Box itself, do not open the Relay Box, but return the unit to your supplier following the return of equipment procedure detailed at the end of this manual.

5.2.1 Replacing the Backing Pump Fuse

If the backing pump fails to operate, backing pump fuse 'F1' may have failed.

Using a small flat blade screw driver, undo and remove the fuse holder marked 'F1' and discard the fuse. Insert a new fuse of the correct rating (refer to [Section 2.1](#)) and refit the fuse holder.

5.2.2 Replacing the Heater Band Fuse

If the heater band fails to operate, either the heater band fuse 'F2' or backing pump fuse 'F1' may have failed (both are required for operation of the heater band).

To replace the backing pump fuse, refer to section above.

To replace the heater band fuse, use a small flat blade screw driver to undo fuse holder 'F2' and remove and discard the fuse. Insert a new fuse of the correct rating (refer to [Section 2.1](#)) and refit the fuse holder.

5.3 Cleaning the Relay Box

If necessary, use a soft dry cloth to clean the exterior of the Relay Box. Do not clean with harsh abrasives or liquids.

This page has been intentionally left blank.

6 STORAGE AND DISPOSAL

6.1 Storage

Store the Relay Box in clean dry conditions in accordance with the technical specifications. Refer to [Section 2](#) of the main manual.

6.2 Disposal

Dispose of the Relay Box and any components safely in accordance with all-local and national safety and environmental requirements.

Alternatively, you may be able to recycle the Relay Box; contact Edwards or your supplier for advice (also see below).

The Relay Box is within the scope of the European Directive on Waste Electrical and Electronic Equipment, 2002/96/EC. Edwards offers European customers a recycling service for the Relay Box at the end of the product's life. Contact Edwards for advice on how to return the Relay Box for recycling.

This page has been intentionally left blank.

7 SERVICE, SPARES AND ACCESSORIES

7.1 Service

A worldwide network of Edwards Service Centres supports Edwards's products. Each Service Centre offers a wide range of options including equipment decontamination; service exchange; repair; rebuild and testing to factory specifications. Equipment, which has been serviced, repaired or rebuilt, is returned with a full warranty.

For more information about service options, contact you're nearest Service Centre or other Edwards company.

7.2 Spares

3 Setpoint free connector kit	D39721071 6
Setpoint free connector kit	D39701001
Heater band fuse	D03103077
Backing pump fuse	301009006

7.3 Accessories

2 m TIC logic interface cable	D3970083
-------------------------------	----------

This page has been intentionally left blank.